

User- and installation manual

Sirius



WARNING - THE COMBUSTION CHAMBER OF THIS STOVE SHOULD ONLY BE OPENED AND SERVICED BY A REGISTERED GAS INSTALLER (i.e. GAS SAFE REGISTERED ENGINEER[GB])

These instructions should be left with the customer for future reference

This Manual Covers the following appliances:

Sirius

Contents

GENERAL INFORMATION.....	3
Important Safety Notice.....	3
General Fitting Information	4
USER INFORMATION.....	5
Remote Control Electronic Ignition System RCE GV60	5
INSTALLER INFORMATION.....	10
Ventilation	10
General Balanced Flue Notes / Appliance Fireplace installation	10
Terminal Locations Wall Mounting	12
Terminal Locations Roof Termination.....	13
Concentric Flue Parts Identification	14
Rigid Balanced Flue Connection Possibilities.....	21
Vertical Roof Terminations	22
Installing Remote Control Electronic Ignition System GV60.....	23
Arranging The Ceramic Fire-bed	24
Log Arrangements	24
Gravel Arrangements.....	25
COMMISSIONING THE APPLIANCE	25
Installation tips.....	26
Installing gasfire Sirius	26
Servicing Instructions	28
Troubleshooting.....	29
TECHNICAL INFORMATION.....	31
Dimensions.....	31
Technical Details.....	32
Warranty.....	35

GENERAL INFORMATION

Important Safety Notice

This appliance has a ceramic Fire-bed arrangement; this contains Refractory Ceramic Fibres, which are man-made vitreous silicate fibres. Excessive exposure to these materials can cause irritation to eyes, skin and respiratory organs. Hence we recommend that when handling these materials the release of dust should be kept to a minimum. During installation and servicing we recommend that a HEPA filtered vacuum be used to remove any dust and soot in and around the fire. If any of the ceramic fire-bed components need to be replaced we recommend that the removed parts be sealed in a heavy-duty polythene bag, and be labelled as RCF waste. RCF is not "Hazardous waste" and can be disposed of at a licensed tipping site for the disposal of industrial waste.

The appliance incorporates a permanent pilot. This is located on the front of the burner, and must not be adjusted by the installer. This system must not be put out of operation, and if any parts require changing, only original manufacturer parts shall be used.

This appliance is designed to be used either Natural or LPG gas however, each individual appliance is only capable of running off the type of gas specified at the time of purchase. It is important to note that once a type of gas has been specified the stove cannot run off any other type. The type of gas that your stove is capable of burning is stated on the data information panel.

This appliance has been designed, tested and approved to meet standards in place for product use, performance and safety. Installation of your appliance must comply with current build-

ing regulations. It is therefore recommend that a registered gas installer be employed for this task. The engineer will provide you with information about the safety limits of the installation and should fix a notice plate in a place where it can be readily seen.

This appliance is designed as an efficient heating device and consequently all body parts become very hot in use. Except for the control knob and control access door, which are designed to stay cool, all other parts are working surfaces and should not be touched.

The glass and frame on this appliance acts as a fireguard conforming to BS: 1945 – 1971 and satisfies the Heating Appliance (Fireguards) regulations 1991. No part of the window or frame should be permanently removed. **It does not give protection for young children aged or infirm**, extra guarding(conforming to BS8423: 2002) should be considered so the special hazards that exist in nurseries and other places where there are young children, aged or infirm persons are minimized.

Bearing in mind that the heat given off by this appliance may affect articles placed close to it, curtains should not be placed within 30cm.

The appliance is not designed as a dryer. It is not therefore recommended that the appliance be used in such a manner. Do not place any articles within 30cm of this appliance as this may result in damage to the articles.

The installation must be carried out in accordance with the following regulations:

The Building Regulations issued by the Depart-

GENERAL INFORMATION

ment of the Environment, the Building Standards (Scotland) (Consolidation) Regulations issued by the Scottish Development Department.

BS 5440 part 1, BS 5871 part 2 and BS 6891.

In the Republic of Ireland the installation must also conform to the relevant standards, particularly in regard to flue sizing and ventilation. Refer to documents IS813, ICP3, IS327 and any other rules in force.

This appliance must be installed in accordance with the rules in force and used only in a sufficiently ventilated space, and is intended for use on a gas installation with a governed meter.

Before installation, ensure that the local distribution conditions (identification of the type of gas and pressure) and the adjustment of the appliance are compatible. The technical specification of this appliance is given on the rear page of this manual.

Do not use the appliance if the glass front door or panel has been broken, removed or is open.

Positioning the appliance

This appliance has been designed to hang against a wall. **This wall must be made of non-combustible and heat resistant material.**

The plaster of the wall has to be resistant to a high temperature. Use therefore the plaster materials especially made for this to prevent discoloring (min. 100 degrees temperature resistant).

If the appliance is to be fitted against a wall with combustible cladding, the cladding must be removed from the area covered, above and around.

As on all heat producing appliances, soft furnishings such as blown vinyl wallpaper placed too near to the appliance may become scorched or discoloured. This should be born in mind when installing the appliance.

Note:

Since the appliance is a source of heat, circulation of air occurs. Therefore it is of importance that you do not use the appliance shortly after a renovation of the home. Because of the natural circulation of air, moist and volatile components from paint, building materials, carpet etc. will be attracted. These components can settle themselves down onto cold surfaces in the form of soot.

General Fitting Information

Inlet pipe connection	8mmcompression
Chimney requirements	Balanced Flue
Flue monitor	Permanent Pilot

User control: Variable rotary control inc. integrated Piezo ignition, Permanent pilot facility, Flame failure device and Oxygen Depletion Cut-out.

Before installation of these appliances, the area into which the fire is to be fitted must be cleared of all debris (including dust), in particular combustible material.

The appliance must sit on a hearth (or base surface) sufficient to support the weight of the fire. The firebox must then also be secured. Adjustable brackets are supplied on the firebox for this purpose.

USER INFORMATION

Remote control electronic ignition system RCE GV60

The appliance is supplied with a remote control. Ignition, controlling the flame height and switching off are performed by the remote control that operates a receiver in the control hatch. For some appliances, no control hatch is supplied. In that case, the receiver is placed under the appliance. The receiver and remote control are battery powered. The receiver requires 4 penlite (AA type) batteries, the remote control requires a 9V block battery. At normal use, the batteries will have an average life of one year. You can also use an optional adapter. Ask your installer for information. In that case you will need a 230 V connection near your appliance.



The appliance's standard functions such as ignition, controlling the flame height, standby (pilot burner) position and switching off are performed in the MAN position, the manual control of the remote control (see fig. 2).

In addition, the remote control can also be used to set a number of additional functions:



- temperature display in degrees Celsius or Fahrenheit;
- time;
- thermostat function;
- timer for thermostat function.

Setting the communication code

Prior to putting the application into operation, a communication code must be set between the remote control and the receiver. The code is chosen randomly from the 65000 available codes. As a result, the chance that other remote controls near you are using the same code and affect the operation of your appliance is very small.

Follow the procedure described below:

Hold down the reset button on the receiver, until you hear two consecutive sound signals (see fig. 2). After the second, longer signal, let go of the reset button.

Press button  (small flame) or button  (large flame) on the remote control within 20 seconds, until you hear an extra long sound signal: this is the confirmation of a correct communication.



!Caution When installing a new remote control or receiver, you must set a new communication code.







USER INFORMATION

MAN position

By briefly pressing the SET button, you will go through the following functions:

MAN →  TEMP →  TEMP → (P*)TIMER
→ MAN

where, depending on the timer setting:

(P*) is displayed as P1  P1  , P2  ,
P2  .

You can also go back to the MAN position by pressing the button  (large flame) or  (small flame).

!Caution - When pressing the buttons (with the exception of the SET button), the transmission symbol () will appear to indicate that transmission is taking place between the remote control and the receiver;

- The receiver acknowledges the transmission with a sound signal;
- The appliance will automatically enter the standby position, if there is no transmission for 6 hours.

Set the remote control to the MAN position.

Ignition

Caution - During the ignition process, you are not allowed to operate control button B on the gas control manually

- Always wait 5 minutes after the pilot burner has gone out, before you re-ignite



Ignite the appliance as follows:
Set button A on the gas control to ON (button B is controlled automatically).

The gas control is located in the control hatch or is placed under the appliance.

Simultaneously press the buttons OFF and  (large flame) on the remote control.

Let go of the buttons when a short sound signal indicates that the ignition process has been started.

In succession:

- the continuous signals will indicate that the ignition process is active;
- a short sound signal will indicate that the ignition process has finished;
- the appliance will automatically switch through to the highest position of the main burner, which will start to burn in a few seconds.



Caution - If the pilot burner is not burning after 3 ignition attempts, you must close the gas tap and call the installer;

- When igniting the pilot burner, you will hear sound signals. After the last short sound signal, the main burner should be largely ignited within about 10 seconds. If this is not the case, you must close the gas tap and warn your installer;
- If the appliance ignites with a pop sound, you must close the gas tap and contact your installer.

!Tip A little motor will start to run when the main burner operates, you will be able to hear it.

USER INFORMATION

Flame height / standby

The flame height can be adjusted continuously by using the buttons  (small flame) and  (large flame). By continuing to lower the flame height, the appliance can be set to the standby position; this means that only the pilot burner will still be burning.

Press button  (small flame) to lower the flame height and/or to set the appliance in the standby position.

Press the button  (large flame) to raise the flame height and/or to switch on the main burner from the standby (pilot burner) position.

Caution - If you continue to press down button  (large flame) on the remote control, the main burner should be largely ignited within about 10 seconds. If this is not the case, you must close the gas tap and warn your installer;

- If the appliance ignites with a pop sound, you must close the gas tap and contact your installer.

Switching off

Switch the appliance off by pressing the OFF button. The pilot burner will also go out.



Temperature display

The room temperature can be indicated on the display in degrees Celsius (°C) using a 24 hour clock or degrees Fahrenheit (°F) using a 12 hour clock.

Simultaneously press OFF and  (small flame), until the correct display appears.

Time

The display can indicate time.

After placing the battery or simultaneously pressing  (large flame) and  (small flame), the time indication will flash on the display and you will be able to adjust the time.

Simultaneously press and until the time indication flashes on the display.



Press the button  (large flame) to set the hours.

Press the button  (small flame) to set the minutes.

Press OFF to return to the MAN position, or wait for the system to automatically return to the MAN position.

Thermostat function

Using the thermostat function you can set two temperatures, which can be controlled thermostatically. These temperatures are referred to as day temperature and night temperature.

The  TEMP and  TEMP symbols on the display refer to day and night temperature respectively.

The room temperature is compared to the set day/night temperature and then the flame height is automatically controlled in order to reach the set temperature.

To be able to use the day/night temperature function, the appliance must be in the standby position.

!Caution - Always leave the remote control at the same place, so that the thermostat is able to 'feel' the room temperature;

- Make sure this place is free from influences such as draught, heat from radiators and direct sunlight.



USER INFORMATION

Example

By using the Y TEMP function you can keep the day temperature at 20 °C; while you use the 4 TEMP function at night to maintain a temperature of 15 °C.



Setting day/night temperature

By using the SET button, you will go through the following functions:



MAN →  TEMP →  TEMP → (P*)TIMER → MAN

Briefly press the SET button to enter the  TEMP or the  TEMP position.

Press the SET button until the temperature on the display flashes.

Set the required temperature by using the buttons  (large flame) and  (small flame).
!Caution - The minimum temperature you can set is 5 °C / 40 °F;

- Control of the night temperature is switched off by lowering the temperature until two stripes (“--”) appear on the display.



Press the OFF button or wait until position  TEMP or  TEMP appears on the display.

Activating the thermostat function

For activating the thermostat function, you must proceed with the following steps:

Place the appliance in the standby (pilot burner) position using button  (small flame).

Set the day/night temperature.

Choose the  TEMP or  TEMP function using the SET button.

Timer for thermostat function

Using the timer enables you to set two times per 24 hours for switching on the day temperature and two times per 24 hours for switching on the night temperature.

In order to control the night temperature, it should be set to at least 5 °C / 40 °F.

If the night temperature is set to the “--” position, the appliance will remain in the standby position.

The appliance will only switch on at the next switch-on time of the day temperature.

The appliance must be in standby position in order to be controlled by the timer.

Example of switch times

You have set a day temperature and night temperature of, for example, 20 °C and 15 °C.

P1  TIMER = 7 hours; the temperature will go to 20 °C at 7 am.

P1  TIMER = 9 hours; the temperature will go to 15 °C at 9 am.

P2  TIMER = 17 hours; the temperature will go to 20 °C at 5 pm.

P2  TIMER = 22 hours; the temperature returns to 15 °C at 10 pm.

USER INFORMATION



Setting times for the timer

To set the timer, proceed as follows:



Set the day and night temperature as described above

Briefly press the SET button to enter the (P*) TIMER position.

Press the SET button until P1  TIMER is displayed and the time flashes.

Set the first switch on time of the day temperature using the buttons  (large flame) and  (small flame).

Briefly press the SET button to set the next time of the cycle, P1  TIMER.

Successively set the times P2  TIMER and P2  TIMER.

Press the OFF button or wait until position (P*) TIMER appears on the display.

Activating the timer function

Follow the steps below for activating the timer control:

Place the appliance in the standby (pilot burner) position using button  (small flame).

Set the day/night temperature if you have not yet done so;

Set the timer times P1  TIMER, P1  TIMER, P2  TIMER and P2  TIMER.

Choose the (P*) TIMER function using the SET button.

Replacing the battery

If the battery is almost empty, the display will show "BATT".

To replace the battery, proceed as follows:

Remove the cover at the back side of the remote control.

Disconnect the 9V block battery from / connect the 9V block battery to the connector.

!Caution - Observe the "+" and "-" poles of the batteries and the connector;

- Use alkaline batteries;

- Batteries are regarded as "small chemical waste" and may therefore not be disposed with the household rubbish.

Place the battery in the holder.

Replace the cover.

INSTALLER INFORMATION

Installation

Before beginning the installation, check that the details on the rating plate correspond to the gas type and pressure to which the appliance will be connected.

Ventilation

This appliance can be installed in a completely sealed or mechanically ventilated house without extra ventilation and/or fume extraction.

General Balanced Flue Notes

There are many possibilities for installing this Concentric Balanced Flue system into a building, both Roof and Wall terminations are possible, and the flue can either be built into an existing chimney or a completely new flue system may be constructed.

The system is based upon a Concentric Flue system which utilises an inner flue of 100 or 130 mm diameter which passes through an outer flue of 150 or 200 mm diameter. The flue gasses that are the products of combustion of the fire, pass through the inner flue and are safely vented to the outside environment. The gap between the inner and outer flues is the channel by which the stove is supplied with air for combustion.

These concentric flues terminate outside of the property in a terminal, this terminal will keep the expelled gasses and the fresh air for combustion separate. It is important that the terminal is not blocked, a suitable guard maybe required if the terminal is located at a "Low" level (usually when the terminal is within 2m of floor level).

The Balanced Flue gas appliance can be installed as an insertion into an existing or new fireplace. If an existing Flue or Chimney is to be utilised, then the installation engineer must be consulted. If the chimney has been previously used it must be professionally cleaned and certified as being sound and fit for use.

The European CE approval on this appliance is

restricted to the Flue systems as specified by the supplier, thus the appliance must only be installed with the original flue system, no others may be used

The gas fire, in combination with the concentric flue system, has been approved in accordance with the European CE-norm for gas appliances and may therefore be used only with this system. The guarantee is invalidated if the appliance is (completely or partially) installed using a different system.

The concentric flue systems can be used with either a newly-built or existing chimney.

These appliances are designed with the "Fire-box" raised up off the ground level by the built in "Base unit".

Thus these appliances require no special Hearth arrangements, as the floor will not get hot and is protected by the steel construction of the "Base unit".

The appliance must not be fitted against a rear wall constructed from a combustible material.

If the appliance has to be located in an opening, a minimum clearance of 50mm should be allowed to non-combustible materials.

The stove must be located at least 280mm from any combustible materials.

Appliance Fireplace Installation

After selecting the appliance location, install a gas connection for the appliance in approximately the desired location of the gas controls.

The gas controls are already connected to the appliance. The controls are located in the control access box, which is located under the fire.

INSTALLER INFORMATION

The appliance and Flue system should be fitted with a minimum clearance of 500mm from any combustible objects or materials, this includes any combustible materials used for the fireplace construction.

The appliance is fully supported off of the rear bracket supplied with the appliance. This bracket must first be securely fixed to the wall with the flue located in the circular cut-out. The appliance can then be secured to this bracket using the supplied fixings. The controls for this appliance are fully housed within the Frame, so no Control Enclosure is required for this appliance.

Timber Frame Construction

Whilst it is possible to install room-sealed appliances in timber frame properties, great care needs to be taken to ensure that the flue assembly does not interfere with the weather proofing qualities of any outer wall which it may penetrate. Before attempting this work, further details need to be referenced, (e.g. "Gas Installations in Timber Frame Buildings" from the CORGI installer series in the UK).

Carport or Building Extension

Where a flue terminal is sited within a carport or building extension, it should have at least two completely open and unobstructed sides. The distance between the lowest part of the roof and the top of the terminal should be at least 600mm.

Note: A covered passageway should not be treated as a carport. Flues should not be sited in a covered passageway between properties.

Basements, Lightwells and Retaining walls

Flue terminals should not be sited within the confines of a basement area, light well or external space formed by a retaining wall, unless steps are taken to ensure the products of combustion can disperse safely at all times. It may be possible to install this Balanced Flue system in such a location provided that it is not sited lower than 1m from the top level of that area to allow combustion products to disperse safely.

Flue terminals should be sited to ensure total clearance of the combustion products in accordance with the included information.

When the products of combustion are discharged, they should not cause a nuisance to adjoining or adjacent properties and they should be positioned so that damage cannot occur to other parts of the building. If the outer wall surface is constructed of combustible material, a non-combustible plate should be fitted behind the terminal projecting 25mm beyond the external edges of the terminal.

INSTALLER INFORMATION

Terminal Locations Wall Mounting

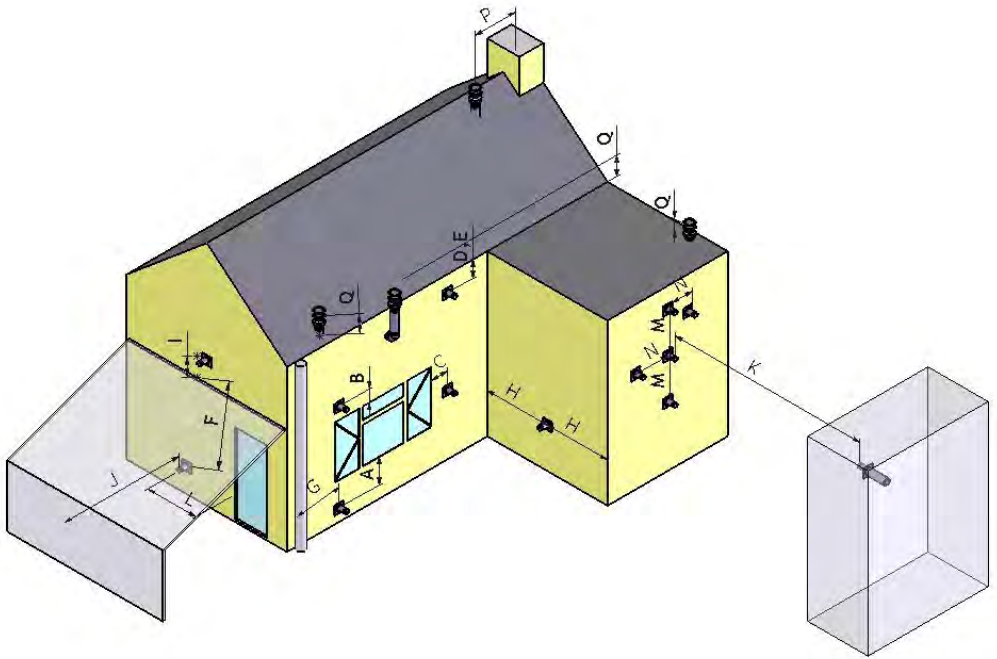

Dimension	Terminal Position	Distance (mm)
A*	Directly below an opening, air brick, opening window etc.	600
B	Above an opening, air brick, opening window etc.	300
C	Adjacent to an opening, air brick, opening window etc.	400
D	Below gutters, soil pipes or drain pipes	300
E	Below eaves	300
F	Below balconies of car port roof	600
G	From a vertical drain pipe or soil pipe	300
H	From an internal or external corner	600
I	Above ground roof or balcony level	300
J	From a surface facing the terminal	600
K	From a terminal facing the terminal	600
L	From an opening in the car port (e.g. door, window into the dwelling)	1200
M	Vertically from a terminal on the same wall	1500
N	Horizontally from a terminal on the same wall	300
P	From a vertical structure on the roof	600
Q	Above intersection with roof	150

* In addition, the terminal should not be nearer than 300mm to an opening in the building fabric formed for the purpose of accommodating a built-in element such as a window frame.

INSTALLER INFORMATION

Terminal Locations Roof Termination

“Distance” = minimum distance required for positioning of the outlet to avoid adverse effects with respect to:

- A. A ventilation opening serving an occupied room, a toilet or a bathroom
- B. A heating air supply, when the supply flows through an occupied room.
- C. A window that can be opened and that is near an occupied room, a toilet or a bathroom.

To avoid adverse effects	Distance: outlet - A,B or C
At the same roof level	>6 m (*)
At a different roof level	>3 m (*) (**)
At a lower positioned wall	>2 m (**)
At a higher sloping surface	>6 m (***)

(*) If the required distance cannot be achieved, the outlet position rules take precedence.

(**) If the outlet is positioned at least 1 m higher than the intake supply opening, or a window that can be opened.

(***) If the required distance cannot be achieved, the position of the outlet must be at least 1 m above the highest facade/roof.

Important note for Roof Terminations (C31).

When installing the appliance with a roof termination (classification C31), it is important to fit a flue restriction strip across the flue outlet inside the stove, see following notes.

Minimum Vertical Length notes.

Roof terminations may be installed from a minimum height 1.0 m this is shown on the pages that follow.

INSTALLER INFORMATION

Concentric Flue Parts Identification

The following pages identify the parts that may be used in the Balanced Flue installation of this appliance.

The Item number in the table refers to the item number of the part in the Identification pages, this Item number is also the number that will be used to identify parts in the Installation suggestion diagrams.

Item	Description	Part No.	
		Ø100	Ø130
A	Appliance		
B	Appliance Connector		
C	Flue Adaptor		
D	Chimney or Flue, Fully Gas Tight Ø150 minimum		
E	Chimney or Flue, Fully Gas Tight Ø160 minimum		
F	Stainless Steel Flexible Chimney Liner Ø100, AISI 316Ti		
G	Stainless Steel Flexible Chimney Liner Ø150, AISI 316Ti		
1	Concentric Flue Pipe 250mm Length	US 25 100	US 25 130
2	Concentric Flue Pipe 500mm Length	US 50 100	US 50 130
3	Concentric Flue Pipe 1m Length	US 100 100	US 100 130
4	Locking Band	USKB 100	USKB 130
5	Protection Band	USAB 100	USAB 130
6	Concentric Flue Pipe Adjustable Length 50 - 300mm	USPP 100	USPP 130
7	Vertical Terminal	USDVC2 100	
8	Horizontal Terminal (Excentric Exit) Ø100	USDHCE 100	
9	Mounting Band	USEB 100	USEB 130
10	Wall Band Adjustable	USMB 100	USMB 130
11	Concentric Flue 90°	USB 90 100	USB 90 130
12	Concentric Flue 45°	USB 45 100	USB 45 130
13	Concentric Flue 15°	USB 15 100	USB 15 130
14	Storm Collar	USSR 100	USSR 130
15	Flat Roof Flashing (Aluminium)	USDPAL 100	USDPAL 130
16	Flat Roof Flashing	USDP 100	USDP 130
18	Slope Roof Flashing 5° - 30°	USDH 100	USDH 130
19	Slope Roof Flashing 20° - 45°	USLS 100	USLS 130
20	Adjustable Roof Plate (Supplied as pair)	USCP 100	USCP 130
21	Wall Cover	USMPG 100	USMPG 130
22	Flue reducer Ø130 - Ø100		USVK 10 130
23	Horizontal Terminal (Excentric Exit) Ø130		USDHC 130
24	Concentric Flue 90° with Inspection Cover	USBI 100	USBI 130
25	Inspection Element	USI 100	USI 130

INSTALLER INFORMATION

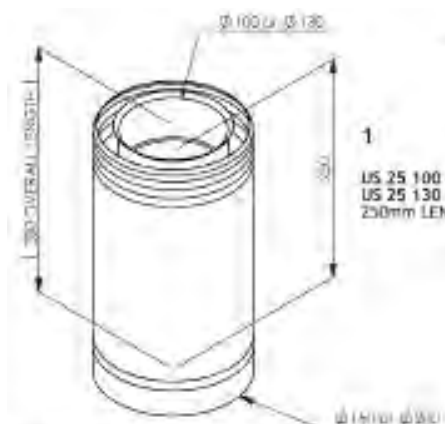

1
 US 25 100 (Ø100)
 US 25 130 (Ø130)
 250mm LENGTH

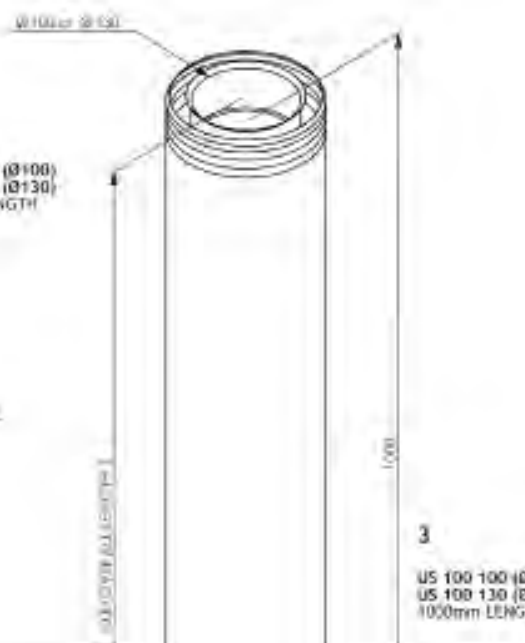

3
 US 100 100 (Ø100)
 US 100 130 (Ø130)
 1000mm LENGTH

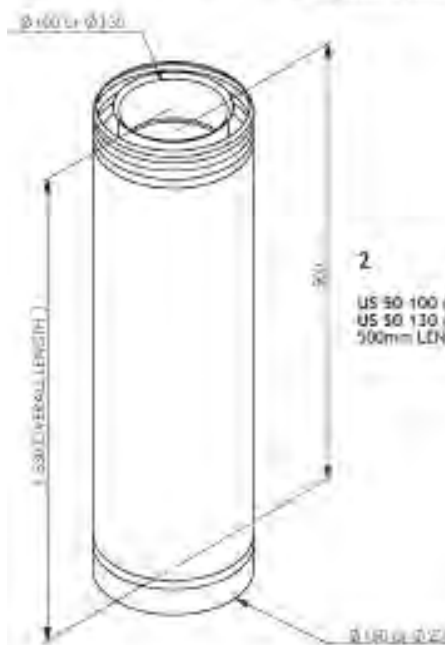

2
 US 50 100 (Ø100)
 US 50 130 (Ø130)
 500mm LENGTH

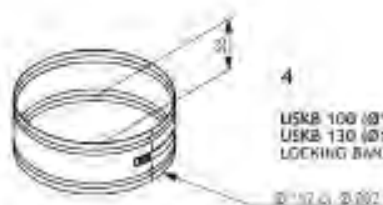

4
 USKB 100 (Ø100)
 USKB 130 (Ø130)
 LOCKING BAND

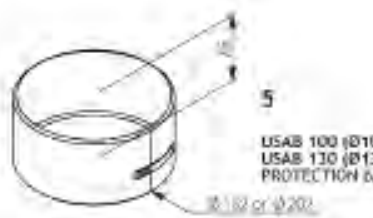

5
 USAB 100 (Ø100)
 USAB 130 (Ø130)
 PROTECTION BAND

INSTALLER INFORMATION

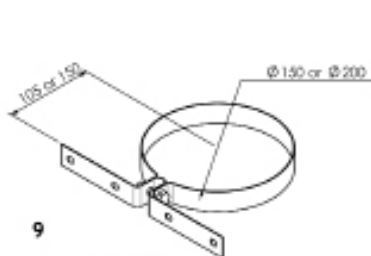
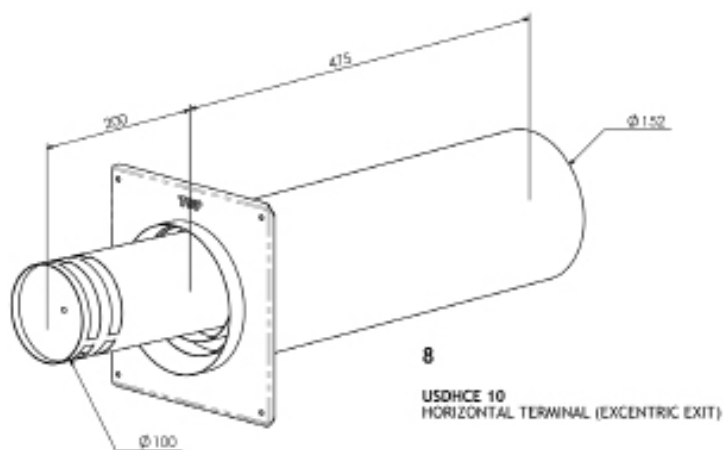
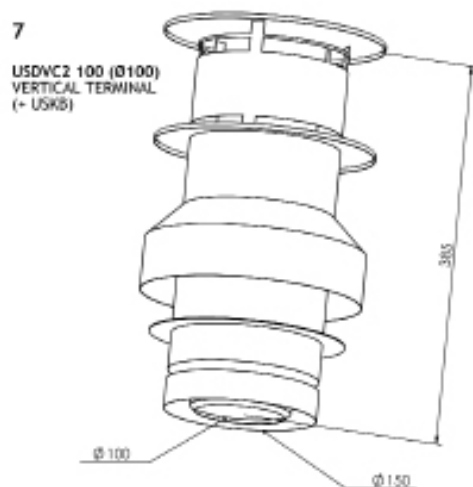
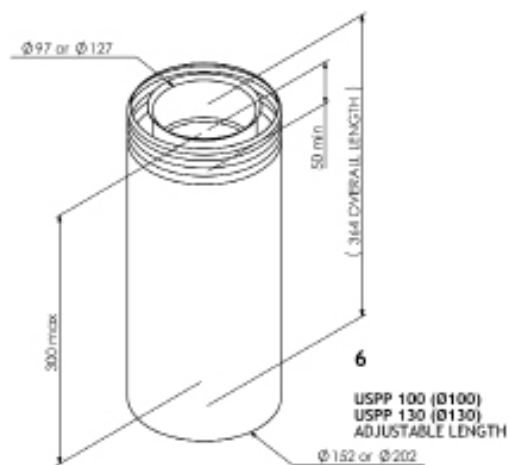

USES 100 ($\varnothing 100$)
 USES 130 ($\varnothing 130$)
 MOUNTING BAND

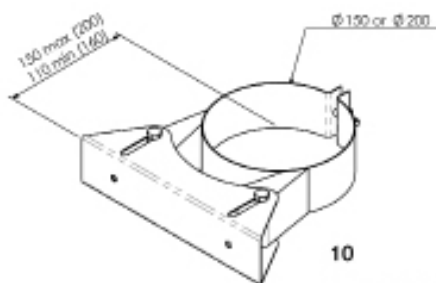

USMB 100 ($\varnothing 100$)
 USMB 130 ($\varnothing 130$)
 WALL BAND ADJUSTABLE

INSTALLER INFORMATION

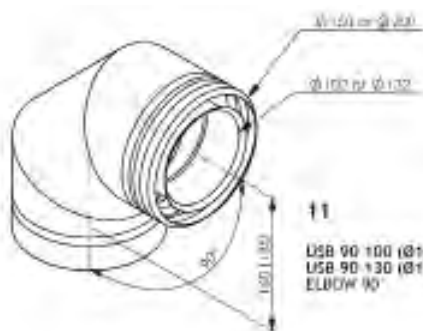

11
 USB 90 100 (Ø100)
 USB 90 130 (Ø130)
 ELBOW 90°

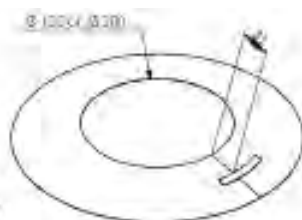

14
 USSR 100 (Ø100)
 USSR 130 (Ø130)
 STORM COLLAR



12
 USB 45 100 (Ø100)
 USB 45 130 (Ø130)
 ELBOW 45°

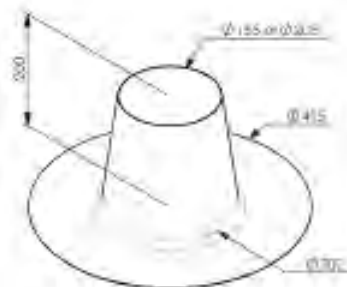

15
 USDPAL 100 (Ø100)
 USDPAL 130 (Ø130)
 FLAT ROOF
 FLASHING ALUMINIUM



13
 USB 15 100 (Ø100)
 USB 15 130 (Ø130)
 ELBOW 15°

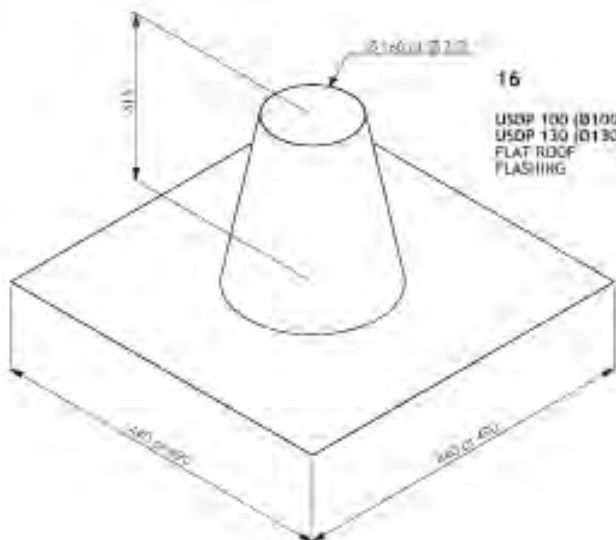

16
 USDF 100 (Ø100)
 USDF 130 (Ø130)
 FLAT ROOF
 FLASHING

INSTALLER INFORMATION

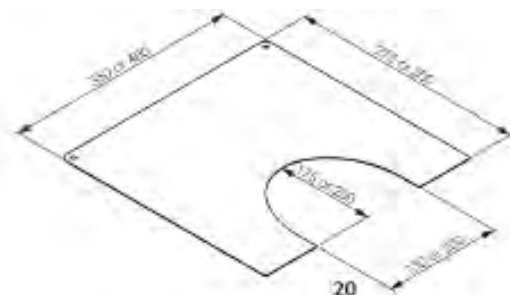

20
 USCP 100 (Ø100)
 USCP 130 (Ø130)
 ADJUSTABLE ROOF PLATE
 (SUPPLIED AS A PAIR)

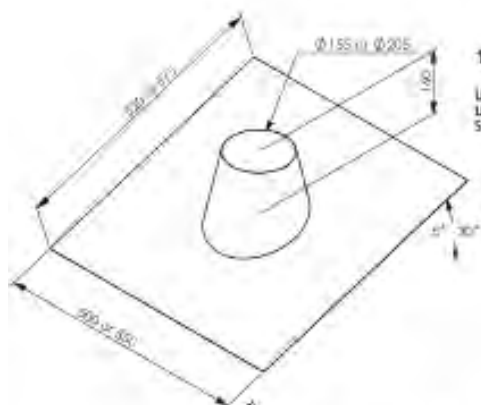

18
 USDH 100 (Ø100)
 USDH 130 (Ø130)
 SLOPE ROOF FLASHING 3' : 30'

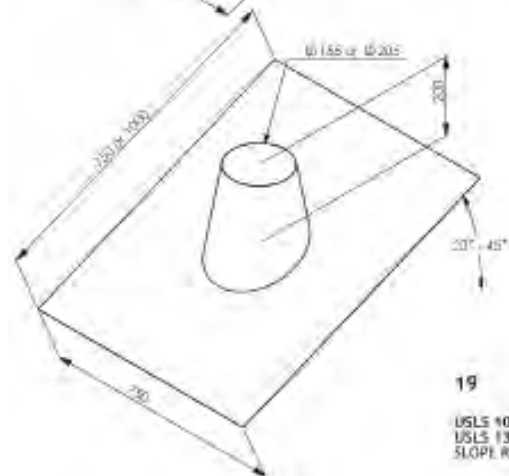

19
 USLS 100 (Ø100)
 USLS 130 (Ø130)
 SLOPE ROOF FLASHING 20' - 45'

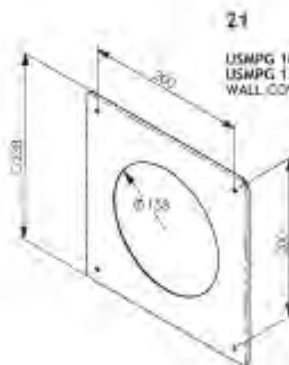

21
 USMPG 100 (Ø100)
 USMPG 130 (Ø130)
 WALL COVER

INSTALLER INFORMATION

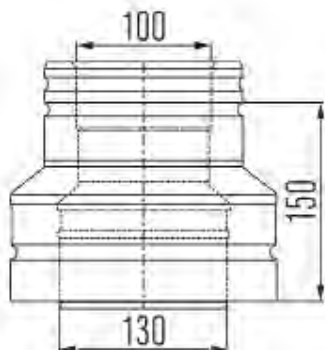

22

USVK 100 130
REDUCER Ø130 - Ø100

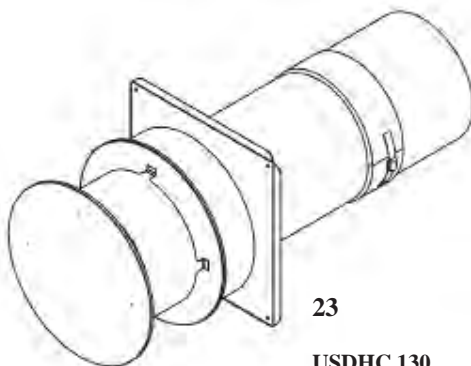

23

USDHC 130
HORIZONTAL TERMINAL Ø130

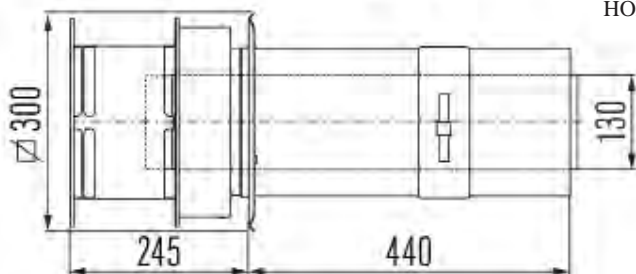

INSTALLER INFORMATION

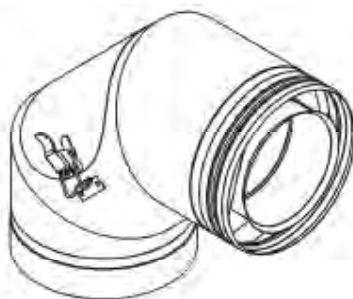
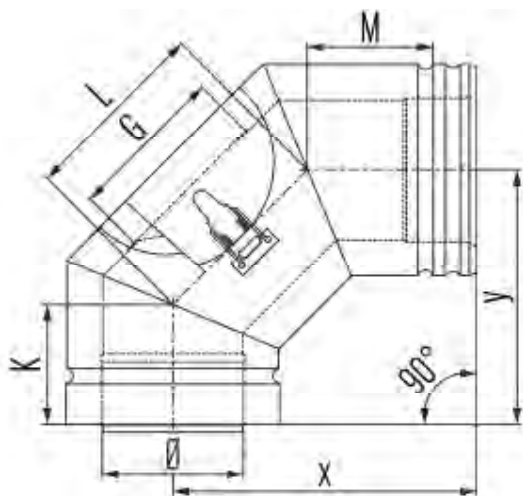

24

USBI 100 130
Elbow 90° with inspection cover

Ø	100	130	G	100	130
K	85	95	x	185	175
L	135	155	y	180	205
M	90	65			

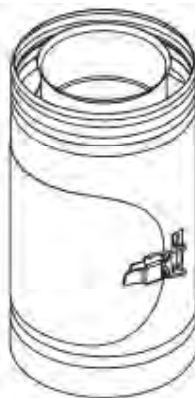
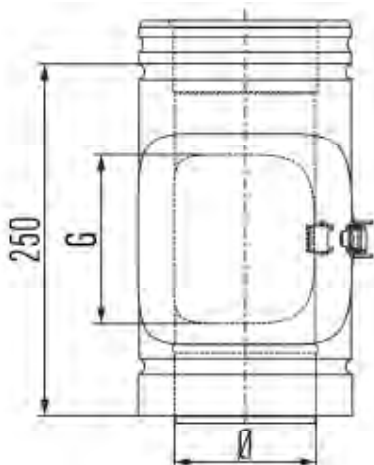

25

USI 100 130
Inspection Element

Ø	100	130
G	100	130

INSTALLER INFORMATION

Rigid Balanced Flue Connection Possibilities

Horizontal Wall Termination

Sirius has a rear back flue and can be installed directly with a wall terminal 200/130. In this situation the maximum horizontal flue is 1.5 meter.

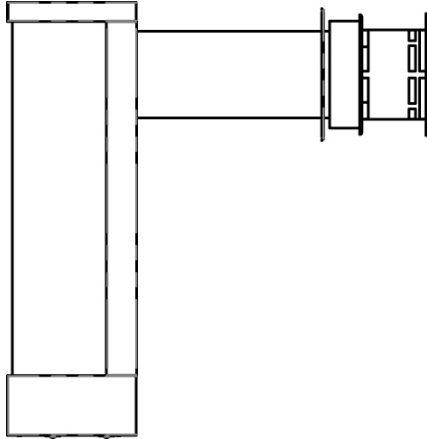

When using a wall terminal it is important to fit the 60 mm flue restrictor across the flue outlet inside the fire.

Horizontal Wall Termination with elbow

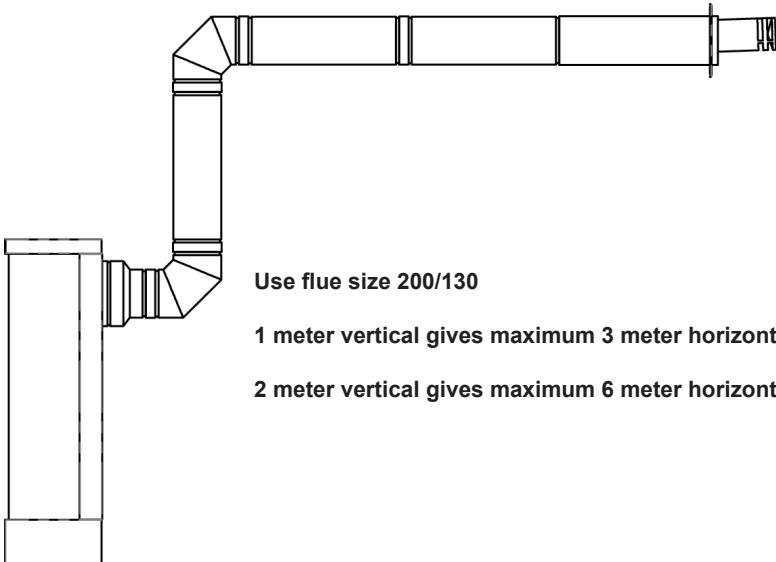

Use flue size 200/130

1 meter vertical gives maximum 3 meter horizontal

2 meter vertical gives maximum 6 meter horizontal

INSTALLER INFORMATION

Vertical Roof Terminations

When installing the appliance with a roof termination (classification 31) it is important to fit a flue restrictor across the flue outlet inside the fire.

Roof terminations will need the 80 mm flue restrictors fitting. This is delivered with the fire.

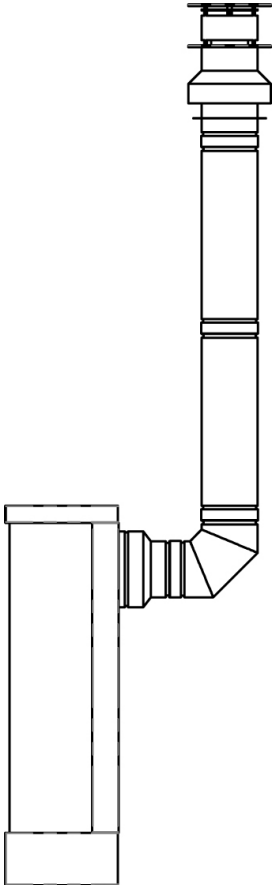

Distance "V" = 1m– 11m (min – max)

**We recommend using flue reducer
USVK to flue dimension 150/100.**

INSTALLER INFORMATION

Installing the controls

Electronic Ignition System RCE GV60)

This requires no external electrical power to operate. The receiver unit has a unit that has only one lead. This lead has one single plug. This plug fits into the connector block on the front of the Gas Control unit, the orientation of this plug is important.

Install the batteries into the receiver and the handset; these will be 4 x 1,5V AA alkaline and 9V PP3 alkaline respectively.

Setting the electronics code:

The receiver has to select the code of the handset, please follow the procedure:

- 1) Power up handset
- 2) Power up receiver (LED flashes)
- 3) Push "reset" button on receiver till long beep
- 4) Push "flame high" or "flame low" button on sender till short beep
- 5) Gas fire is now ready for ignition. See options in user part.

The receiver unit can be hidden away under the stove, ensure that the customer knows where the receiver is for future battery replacement.

Check the system.



INSTALLER INFORMATION

Log Arrangements - Sirius

Only the ceramics supplied with this appliance are to be used. The ceramics must be laid only as shown on this page. Replacement parts are available from your dealer, but should only be installed by a qualified installation engineer.

Ensure that the grate is sitting firmly in the base of the fire box, with the long slot in the centre of the Grate aligning with the centre slots on the Burner Tube. The Pilot flame must be visible through the grate and the cut-out in the Pilot Shield. Make sure there is a 1 cm gap between the back log and the back wall of the fire.



Ensure that a number of holes in the Grate and the Pilot area are free of embers.

After placing the embers and logs according to the figures sprinkle some ashes over the logs and embers.

Finally check the pilot is clear, no embers have entered the Pilot area and the cross lighting is good before the glass is replaced.



INSTALLER INFORMATION

Gravel Arrangements / Blackstones / Commissioning the appliance Brilliants

Ensure that the Grate, is sitting firmly in the base of the fire box, with the long slot in the centre of the Grate aligning with the centre slots on the Burner Tube. The Pilot flame must be visible through the grate and the cut-out in the Pilot Shield.

Scatter evenly the Gravel over the top of the Grate and Burner. Make sure that some holes of grate are still visible. Ensure that none of the gravel enters the pilot enclosure.



Gravel Arrangement

The Gravel arrangement is now complete, **However, it is important to check that no stones have entered the pilot area and the cross lighting is good before the glass is replaced.**



Detail showing Pilot Area with no gravel

A soundness test **MUST** be made before the installed stove is left with the customer.

Ensure that the fire is burning at full rate for a minimum of 5 minutes to warm the flue.

If there are problems, the flue may require attention.

The stove will produce an odour and/or smoke for the first few hours of use. Please ventilate the room. Also please note that during this initial burning period, a grey dust deposit will be formed on the inside of the window, please clean this before leaving the appliance with the customer.

INSTALLER INFORMATION

INSTALLATION TIPS

Please read first the general fitting information which one can find on page 4 of this booklet.

This appliance has been designed to hang against a non combustible wall.

The plaster of the outside has to be resistant to a high temperature. Use therefore the plaster materials especially made for this, to prevent discoloring. (min. 100 degrees C temperature resistant.)

If the appliance is to be fitted against a wall with combustible cladding, the cladding must be removed from the area covered above, and around.

Installing gasfire Sirius

The Sirius is delivered in a crate, which can be opened by taking out the 4 screws at the sides of the bottom of the crate. The top part of the crate can now be lifted easily.

Lifting the fire from the crate;

The fire and wall bracket is placed between 2 wooden blocks. **Always lift the fire from the crate with 2 persons.**

Removing the front glass;

Remove the metal bottom plate of the fire after taking out the two bottomscrews. Then remove the 3 screws to remove the bottom frame of the fire.

Remove the top frame by sliding it of.

Remove the 4 small corner bracketts which keep the glass together on the corners.

Now slightly undo the bolts of the metal bracketts which clamp the glas against the fire, bottom, top, left and right, so the glass front can be removed carefully.

Installing the wall brackett:

Determine the position for the flue and fix the metal wall plate to the wall with the flue located in the center of the circular cut out. **The wall should be made out of non-combustible materials only.** You can hang the fire on the wall plate. For this purpose the wall plate has brackets and the Fire has some slots.

INSTALLER INFORMATION

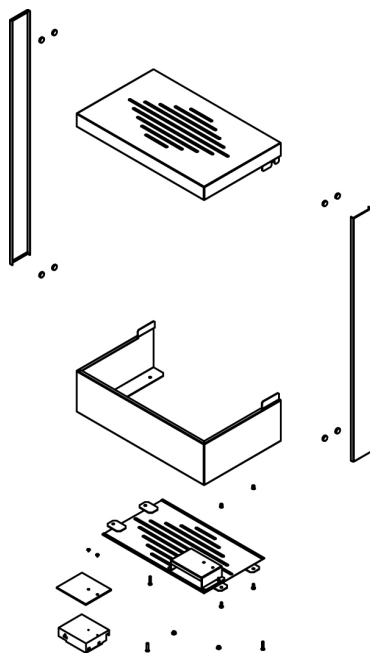

Installing the flue restrictor;

When using a wall terminal install the 60 mm flue restrictor.

When using a roof terminal install the 80 mm flue restrictor.

The 60 mm flue restrictor is located inside the fire. Undo one of the screws and slide the restrictor over the flue outlet.

The 80 mm flue restrictor is delivered separately with the appliance.

Mounting the cover plate of the flue outlet:

Now place the cover plate in front of the flue outlet using the slots in the fire.

Installing the fire

Connect the fire to the gaspipe. Install the GV60 remote control set and test the appliance. Now the log set can be placed following instructions on page 26.

CHECK CORRECT WORKING OF THE APPLIANCE

Mounting the frame:

After checking of proper working of the fire the metal bottom frame can be placed over the glass and tightened with the screws. Then mount the bottom plate again. Place the top frame over the glass and click the metal side panel, using the magnets, on their positions.

SERVICING INFORMATION

Servicing instructions

The following outlines only the minimum work that should be performed on an annual basis. This service work, like any other work on the appliance, must only be done by a qualified and competent engineer who is Gas Safe registered.

Open the door and remove all ceramics.

Remove Grate from the firebox.

Remove any debris from the top of the burner using a vacuum cleaner and brush.

Inspect the burner unit.

Perform an ignition check.

Perform a flame failure check

There should be no need to service the burner. If however this is required, then the engineer should check the setting pressure at inlet to burner; the correct pressure is shown at the rear of the manual.

Brush off and replace ceramic arrangement as earlier in this manual, replacing any broken or damaged pieces.

Check all seal on door (including glass) and replace the Door.

Check the installation for gas leaks.

Check flue for clearance of products of combustion.

If any parts need to be replaced use only genuine manufacturer parts, non-standard parts will invalidate the guarantee and may be dangerous.

Troubleshooting

On the next pages you will find remedies for problems which may occur when using fires with full electronic ignition RCE GV60

Figures troubleshooting

Figure 1

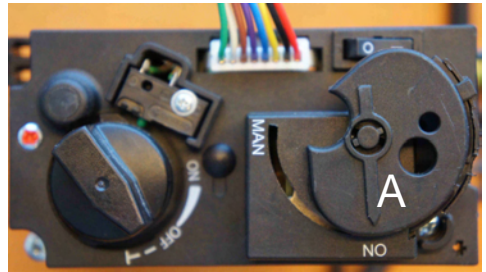
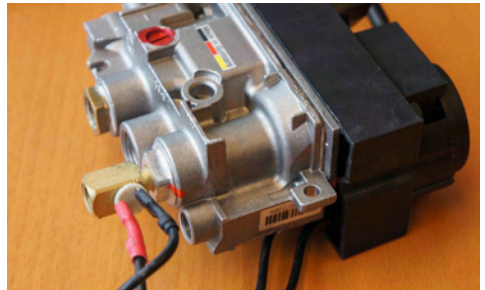

Figure 2



TROUBLE SHOOTING

"Problem"	"Possible cause"	"Remedy"
A. No transmission (motor will not run)	<ol style="list-style-type: none"> 1. The (new) communication code between receiver and remote control must still be confirmed. 2. Empty batteries. 3. Receiver is damaged. 4. Remote control is damaged. 5. Motor cable at valve/receiver is broken. 6. Bent pins of the 8-wire connector. 7. If the receiver is surrounded by metal, this could decrease the transmission range. 	<ol style="list-style-type: none"> 1. Hold down the reset button of the receiver, until you hear a long beep . Let go of the reset button after the second, longer sound signal and press button (small flame) or button (large flame) on the remote control within 20 sec., until you hear an extra long sound signal confirming that the new code has been set. 2. Replace batteries. !Caution Avoid short circuit between the batteries and metal parts of the appliance. 3. Replace the receiver and confirm the code (remedy 1). 4. Replace the remote control and confirm the code (remedy 1). 5. Replace the motor cable. 6. Make sure that the pins of the 8-wire connector are straight. 7. Change the position of the antenna.
B. No ignition (spark)	<ol style="list-style-type: none"> 1. Button A in position MAN. 2. Ignition cable runs over and/ or alongside metal parts. 3. Ignition pen corroded. 4. 60-second delay before the full restart is not yet finished. 	<ol style="list-style-type: none"> 1. Switch button A on the gas control to ON (figure 1) 2 Do not place the ignition cable over and/or along metal parts. This will weaken the spark; If necessary, replace the ignition cable. 3. Replace the ignition pen. 4. Wait until the delay time has passed.
C. No sound signal	<ol style="list-style-type: none"> 1. Receiver is damaged. 2. 60-second delay before the full restart is not yet finished. 	<ol style="list-style-type: none"> 1. Replace the receiver and confirm the code (remedy 1 at A) 2. Wait until the delay time has passed.
D. One continuous sound signal of 5 sec. (Possible 7 short beeps prior to the 5 sec. sound signal)	<ol style="list-style-type: none"> 1. Loose wiring between receiver and gas control. 2. Receiver is damaged. 3. Bent pins of the 8-wire connector. 4. Damaged magnetic valve. 	<ol style="list-style-type: none"> 1. Connect the wiring properly. 2. Replace the receiver and confirm the code (remedy 1 at A) 3. Make sure that the pins of the 8-wire connector are straight. 4. Replace the gas control.
E. No pilot burner flame	<ol style="list-style-type: none"> 1. Air in the pilot burner pipe. 2. Wires of thermocouple have been cross-connected. 3. No spark at the pilot burner. 4. Injector is blocked up. 	<ol style="list-style-type: none"> 1. Flush the pipe or start the ignition process several times. 2. Check the polarity of the thermocouple wiring. Connect the thermocouple wiring properly, if necessary. 3.1 Check if the ignition cable is lying free from metal parts; If necessary, move it away from the metal parts. 3.2 If necessary, replace the ignition cable. 3.3 If necessary, replace the ignition pen. 4.1 Clean the injector. 4.2 If necessary, replace the injector.

TROUBLE SHOOTING

“Problem”

F. Electronics keep sparking while the pilot burner is ignited

G. Pilot burner is burning, but magnetic valve closes after ca. 10 seconds or when the appliance gets hot

H. There are short sound signals, but no sparks and no sound / clicks can be heard of the magnet opening the valve

I. Pilot burner is burning, but there is no gas flow to the main burner

J. Main burner ignites, but goes out again after approx. 22 seconds

“Possible cause”

1. Receiver is damaged.

1. Thermocouple does not function.

2. Batteries (almost) empty.

1. Batteries (almost) empty.

1. Button A in position MAN.
2. Appliance in the pilot flame position.
3. Pre-pressure of the gas is too low.
4. Damaged magnetic valve.

1. Wiring of thermocouple is loose.
2. Wires of thermocouple have been cross-connected.
3. Short-circuit in the wiring of thermocouple
4. Broken wire in the wiring of thermocouple
5. Thermocouple is dirty.
6. Thermocouple is not positioned correctly in the flame
7. Thermocouple is defective.

8. Receiver is defective.

“Remedy”

1. Replace the receiver and confirm the code (remedy 1 at A)

1.1 Measure the voltage, using a digital mul-timeter, set to mV range, by connecting the cables to the cable shoe. The cable shoe is located on the outside, directly next to the magnet nut at the rear of the gas control;

The voltage should be at least 5mV within 20 seconds.

It may not be lower when the appliance is warm.

If the voltage is too low:

- the thermocouple should be placed better in the flame or

- the thermocouple should be replaced.

1.2 Check the size of the pilot burner flame.

Correct a flame that is too small.

1.3 Check the wiring of the thermocouple to the receiver.

If necessary, replace the wiring.

2. Replace the receiver's batteries.

!Caution Avoid short circuit between the batteries and metal parts of the appliance.

1. Replace the receiver's batteries.

!Caution Avoid short circuit between the batteries and metal parts of the appliance.

1. Turn button A on the gas control to ON
2. Increase the flame height by pressing button (large flame) on the remote control.
3. Check pre-pressure.

If necessary, contact gas company.

4. Replace the gas control.

1. Connect the wiring properly.(figure 2)
2. Connect the wiring properly. (figure 2)

3. Replace wiring.

4. Replace wiring.

5. Clean the thermocouple.

6. Position the thermocouple correctly in the flame.

7. Check the voltage across thermocouple just before the main burner goes out. If the voltage is lower than 1.8 mV, replace thermocouple

8. Check the voltage across thermocouple just before the main burner goes out. If the voltage is higher than 1.8 mV, replace the receiver.

TECHNICAL INFORMATION

Technical drawing Sirius



TECHNICAL INFORMATION

Countries of Destination

The following table gives detail of the Countries that these appliances are approved for use within. The tables following immediately on give the technical characteristics of the appliances.

		Natural
AT	Austria	✓ I2H G20@20mbar
BE	Belgium	✓ I2E+ G20/G25@20/25mbar
CH	Switzerland	✓ I2H G20@20mbar
CZ	Czech Republic	✓ I2H G20@20mbar
DE	Germany	✓ I2E G20@20mbar; I2ELL G20/G25@20mbar
DK	Denmark	✓ I2H G20@20mbar
EE	Estonia	✓ I2H G20@20mbar
ES	Spain	✓ I2H G20@20mbar
FI	Finland	✓ I2H G20@20mbar
FR	France	✓ I2E+ G20/G25@20/25mbar
GB	United Kingdom	✓ I2H G20@20mbar
GR	Greece	✓ I2H G20@20mbar
HR	Croatia	✓ I2H G20@20mbar
HU	Hungary	
IE	Ireland	✓ I2H G20@20mbar
IT	Italy	✓ I2H G20@20mbar
LT	Lithuania	✓ I2H G20@20mbar
LU	Luxembourg	✓ I2E G20@20mbar
LV	Latvia	✓ I2H G20@20mbar
NL	The Netherlands	✓ I2L G25@25mbar
NO	Norway	✓ I2H G20@20mbar
PL	Poland	✓ I2E G20@20mbar
PT	Portugal	✓ I2H G20@20mbar
RO	Romania	✓ I2H G20@20mbar
SE	Sweden	✓ I2H G20@20mbar
SL	Slovenia	✓ I2H G20@20mbar
SK	Slovakia	✓ I2H G20@20mbar
TR	Turkey	✓ I2H G20@20mbar

TECHNICAL INFORMATION

LPG		
AT	Austria	✓ I3B/P G30/G31 @50mbar
BE	Belgium	✓ I3+ G30/G31 @28-30/37mbar
CH	Switzerland	✓ I3B/P G30/G31 @50mbar, I3+ G30/G31 @28-30/37mbar
CY	Cyprus	✓ I3B/P G30/G31 @30mbar
CZ	Czech Republic	✓ I3B/P G30/G31 @50mbar, I3+ G30/G31 @28-30/37mbar
DE	Germany	✓ I3B/P G30/G31 @50mbar
DK	Denmark	✓ I3B/P G30/G31 @30mbar
EE	Estonia	✓ I3B/P G30/G31 @30mbar
ES	Spain	✓ I3+ G30/G31 @28-30/37mbar
FI	Finland	✓ I3B/P G30/G31 @30mbar
FR	France	✓ I3B/P G30/G31 @30mbar, I3+ G30/G31 @28-30/37mbar
GB	United Kingdom	✓ I3B/P G30/G31 @30mbar, I3+ G30/G31 @28-30/37mbar
GR	Greece	✓ I3B/P G30/G31 @30mbar, I3+ G30/G31 @28-30/37mbar
HR	Croatia	✓ I3B/P G30/G31 @30mbar
HU	Hungary	✓ I3B/P G30/G31 @30mbar
IE	Ireland	✓ I3+ G30/G31 @28-30/37mbar
IT	Italy	✓ I3+ G30/G31 @28-30/37mbar
LT	Lithuania	✓ I3B/P G30/G31 @30mbar
LU	Luxembourg	
LV	Latvia	
MT	Malta	✓ I3B/P G30/G31 @30mbar
NL	The Netherlands	✓ I3B/P G30/G31 @30mbar
NO	Norway	✓ I3B/P G30/G31 @30mbar
PL	Poland	
PT	Portugal	✓ I3+ G30/G31 @28-30/37mbar
RO	Romania	✓ I3B/P G30/G31 @30mbar
SE	Sweden	✓ I3B/P G30/G31 @30mbar
SL	Slovenia	✓ I3B/P G30/G31 @30mbar
SK	Slovakia	✓ I3B/P G30/G31 @30,50mbar, I3+ G30/G31 @28-30/37mbar
TR	Turkey	✓ I3B/P G30/G31 @30mbar

TECHNICAL INFORMATION

Element4, a manufacturer of gas heating appliances, develops and produces products that comply with the highest quality, performance and safety requirements. This guarantees that the user will be able to enjoy using his product for many years to come.

This appliance has a CE marking, which means that it complies with the essential requirements of the European gas appliance directive. As an installer, you must be competent in the field of atmospheric gas heating.

This manual discusses the installation of the appliance and the regulations that apply to the installation. In addition, you will find technical data for the appliance and information on maintenance, any malfunctions that might occur and their possible causes. Please carefully read and use this installation manual.

We hereby declare that the design and construction of Element4's atmospheric gas heating appliance comply with the essential requirements of the Gas Appliance Directive.

Product: atmospheric gas heating appliance

Type: Sirius

Applicable EEC directives: 90/396/EEC

Applied harmonized standards: NEN-EN-613

NEN-EN-613/A1

Internal measures by the company guarantee that appliances produced in series comply with the essential requirements of the prevailing EEC directives and the standards derived from them. This declaration will lose its validity if adjustments are made to the appliance, without prior written permission by Element4.

Sirius		PIN: 0558CM1329		
	Natural Gas		LPG	
Gas Category	I2H		I3B/P	I3+
Supply Pressure (mbar)	20		30	28-30/37
Nominal Input (Gross kW)	9,7		8,8	8,8
Efficiency Class	1		1	1
Pilot Burner	446.0330.14		446.0330.07	446.0330.07
Gas Rate (max.m3/hr)	0.924		0.252	0.252
Burner Pressure (mbar-hot)	18.8		28.4	28.4
Injector Marking	650		260	260
NOX Class	3		2	2

WARRANTY

Warranty

The warranty for your Element4 appliance will be provided by your supplier. In case of complaints, you must always contact him. Your supplier will contact Element4 if necessary.

The factory warranty is valid for 12 months after date of purchase.



Element4 B.V.
Paxtonstraat 23
8013 RP Zwolle
The Netherlands